

Kidde WHDR™ Agent Discharge Nozzles

P/N 87-1200XX-001

Effective: March 2018
K-87-011 Rev AG

FEATURES

- For Use in WHDR™ Commercial Cooking Fire Suppression Systems
- Stainless Steel Internal Strainer
- Nickel-Chrome Plated Brass Body
- Grooved Rings for Easy Identification
- Foil Seal Prevents Clogging from Grease
- Available Swivel Adapter for Easy Aim Adjustment

DESCRIPTION

There are seven agent discharge nozzles available for use with the Kidde WHDR Wet Chemical Suppression System. Each nozzle has a specific flow number which is an indication of the discharge rate. Nozzle types are selected based upon the specific hazard being protected (see Table 1). All nozzles have a 3/8-in. NPT female thread and are stamped with the nozzle type (see Figure 1).

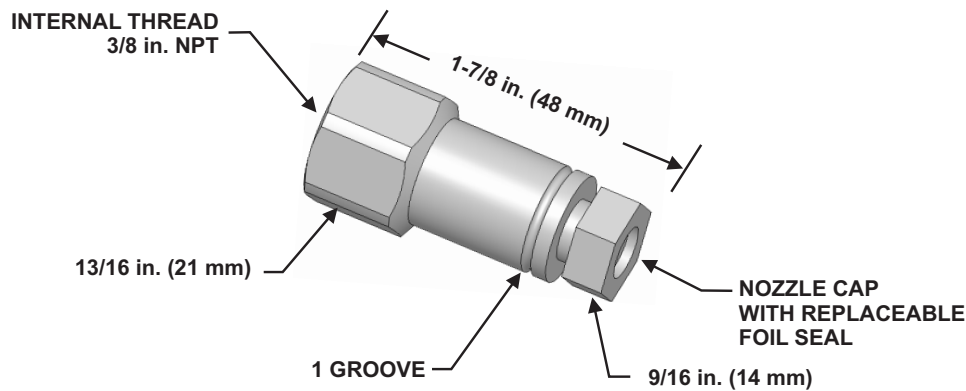

Figure 1. ADP Nozzle

All nozzles include a threaded cap with a replaceable foil seal (P/N 60-9197054-000). The foil seal prevents contamination, while eliminating the potential for hanging caps.

An optional swivel adapter (P/N 87-120021-001) may be used with each nozzle to facilitate proper aim (see Figure 2).

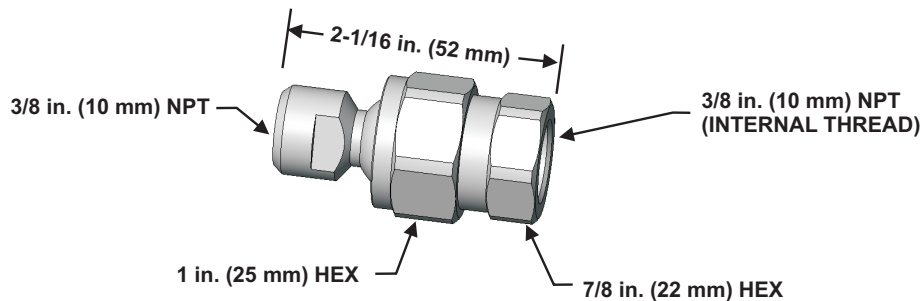

Figure 2. Nozzle Swivel Adapter

Table 1: Nozzle Application Information

Nozzle Type	Part Number	Flow	Part Number	Grooves	Application
ADP		1	87-120011-001	1	Split Vat Deep Fat Fryer (Low Proximity) Krispy Kreme Model 270 d/h Doughnut Fryer Upright and Salamander Broiler Natural or Mesquite Charcoal Charbroiler Chain Broiler (Open and Closed Top) Griddle With or Without Raised Ribs Plenum and Duct
F		2	87-120012-001	2	Single Vat Deep Fat Fryer Split Vat Deep Fat Fryer Lava Rock Charbroiler (Lava, Pumice, Ceramic, or Synthetic Rock) Gas Radiant/Electric Charbroiler Tilt Skillet (Braising Pan)
GRW		1	87-120013-001	3	Gas Radiant/Electric Charbroiler Wok
R		1	87-120014-001	4	Four-Burner Range Two-Burner Range Single-Burner Range
DM		3	87-120015-001	0	Mesquite Log Charbroiler
LPF		2	87-120022-001	1 & 4	Single Vat Deep Fat Fryer (Low Proximity)
LPR		1	87-120024-001	Disc & Core	Four-Burner Range (Low Proximity)

ORDERING INFORMATION

Description	Part Number
ADP Nozzle	87-120016-001 (10-pack of 87-120011-001)
F Nozzle	87-120017-001 (10-pack of 87-120012-001)
GRW Nozzle	87-120018-001 (10-pack of 87-120013-001)
R Nozzle	87-120019-001 (10-pack of 87-120014-001)
DM Nozzle	87-120020-001 (10-pack of 87-120015-001)
LPF Nozzle	87-120023-001 (10-pack of 87-120022-001)
LPR Nozzle	87-120025-001 (10-pack of 87-120024-001)
Swivel Adapter	87-120021-001 (each)
Foil Seals	60-9197054-000 (10-pack)
Disc Cap	60-9197290-000 (10-pack, not for LPR nozzle)
Disc Cap, LPR	87-120026-001 (each, for LPR nozzle only)

EXPORT INFORMATION (USA)

Jurisdiction: EAR
Classification: EAR99

This document contains technical data subject to the EAR.

All trademarks are the property of their respective owners.

This literature is provided for informational purposes only. KIDDE-FENWAL, INC. believes this data to be accurate, but it is published and presented without any guarantee or warranty whatsoever. KIDDE-FENWAL, INC. assumes no responsibility for the product's suitability for a particular application. The fire suppression system design, installation, maintenance, service and troubleshooting must be performed by trained, authorized Kidde Fire Systems distributors for the product to work correctly. If you need more information on this product, or if you have a particular problem or question, contact: KIDDE-FENWAL, INC., Ashland, MA 01721 USA, Telephone: (508) 881-2000.

